



## PE24GVA VALVE ACTUATOR

Installation and Operation Manual

### SAFETY SECTION

#### **⚠ WARNING Risk of Fire or Electric Shock**

- To be connected to a Class 2 circuit only.
- All wiring must comply with all state and local electrical codes including the National Electrical Code and/or Canadian Electrical Code.

#### **⚠ AVERTISSEMENT Risque d'incendie ou d'électrocution**

- À brancher uniquement à un circuit de catégorie 2.
- Tous les câbles doivent être conformes à l'ensemble des codes électriques étatiques et locaux, y compris le Code national de l'électricité et/ou le Code canadien de l'électricité.

### PRODUCT DESCRIPTION

Simplify pool and spa automation applications with the PE24GVA valve actuator from Intermatic. The 24-volt valve actuator provides infinite cam adjustment to streamline installations while accommodating a wide range of water flow needs. Designed for pool professionals and homeowners alike, the PE24GVA features an updated design and intuitive features that take the hassle out of cam adjustments.

#### Specifications

Electrical Ratings:

- 24 V, 60 Hz, 0.75 A

Normal Operation Duty Cycle:

- 1 minute ON (Max), 8 minutes OFF (Min)

These values may be temporarily exceeded during installation testing and adjustment.

### INSTALLATION

#### Mounting Actuator on Top of Pool and Spa Diverter Valve

1. Unscrew the hold-down knob and remove handle from diverter valve shaft. (See figure 4 below for hold down knob and valve handle identification) Existing knob must be replaced with knob provided with Intermatic actuator.
2. With a Phillips screwdriver, remove the four screws from the valve body as shown in Figure 1.
3. Turn the actuator over and observe the teeth as shown in Figure 2.
4. Place the actuator over the valve shaft so the small tooth engages with the small slot in the valve shaft. See Figure 2.
5. Rotate the actuator while keeping the two shafts engaged until the screw holes on the actuator legs align with the empty screw holes (see step 2) in the valve.
6. Use the (4) supplied long stainless steel screws to attach the actuator to the valve.
7. Use hold down knob provided with Intermatic actuator to connect the handle to the actuator shaft. Do not overtighten. Finger tighten only.
8. Connect power supply cord to a CLASS 2 CIRCUIT ONLY, rated 24 V nominal, 4 A or 100 VA maximum.

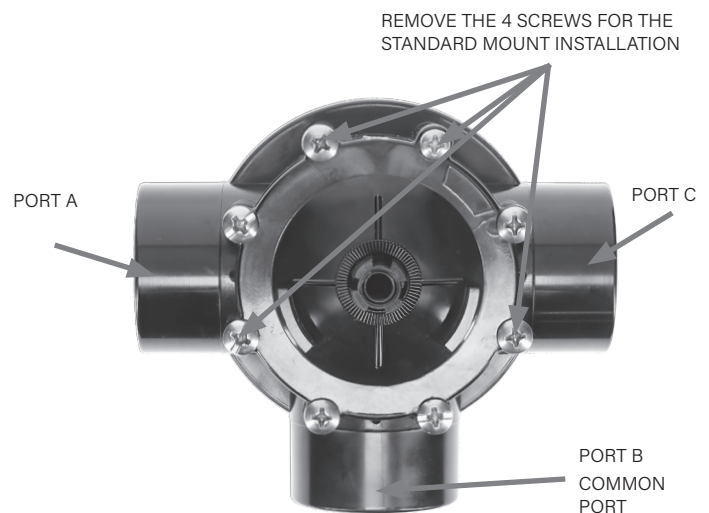

Figure 1.

# INSTALLATION

## Mounting Actuator on Top of Pool and Spa Diverter Valve Continued

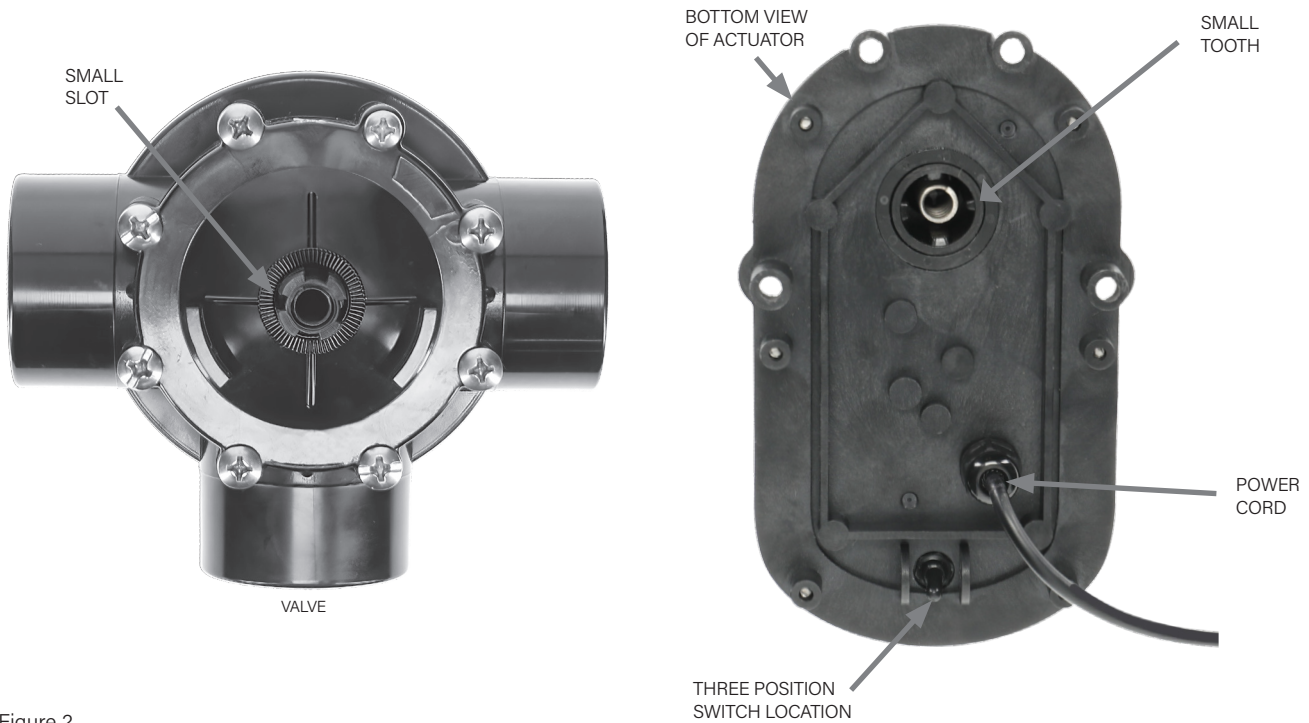

Figure 2.

### Mounting Options

Standard Plumbing - A three-port valve is the port B (middle) being the incoming (common) port and A and C ports are the outlet ports (see Figure 1).

Standard Actuator Mounting - The main body of the actuator is over port B as shown in position 1 of Figure 3.

The actuator can also be mounted on top of a valve in four different positions as shown in Figure 3. Depending on the plumbing of the valve and mounting position of the actuator, the cams inside the actuator may have to be reset. (See next section.)

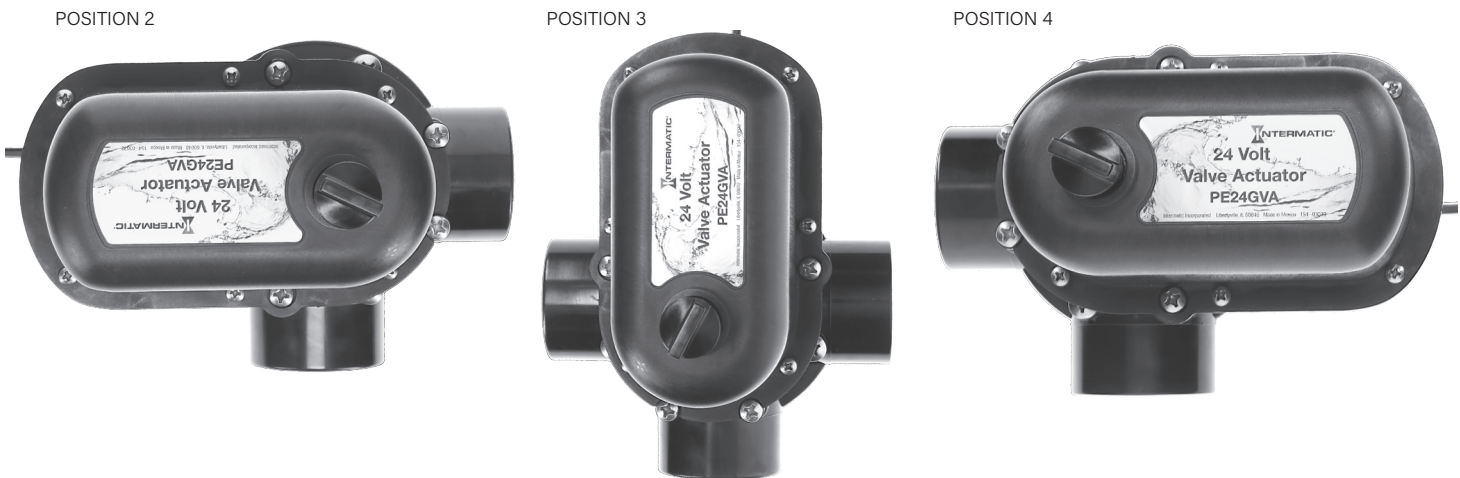
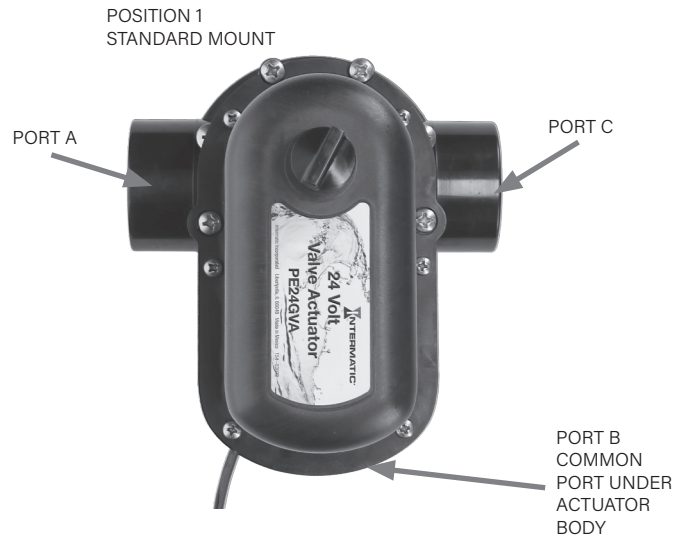

Figure 3.

## CAM Setting

**NOTE:** Factory settings: If mounted in POSITION 1 (STANDARD MOUNT in FIG 3) the cams will stop the valve blocking PORT A in one direction and PORT C in the other direction. If the valve is plumbed in the Standard Plumbing position and the actuator is in Standard Mounting position there is no need for resetting the cams. If needed be sure to adjust the cams to match your setup.

For cam adjustment first remove the hold down knob and handle (see FIG 4). Then remove six screws and actuator lid to expose the cam/motor compartment (see FIG 4). Next, follow the step by step illustrations as shown below.

1. Activate the bottom switch to check the clockwise stopping point.

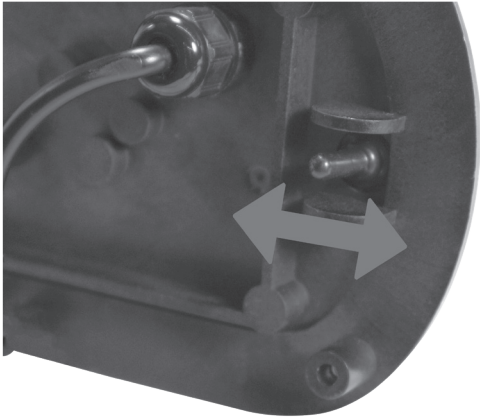

2. Clockwise rotation stops when the top cam lobe makes contact with the top switch point.

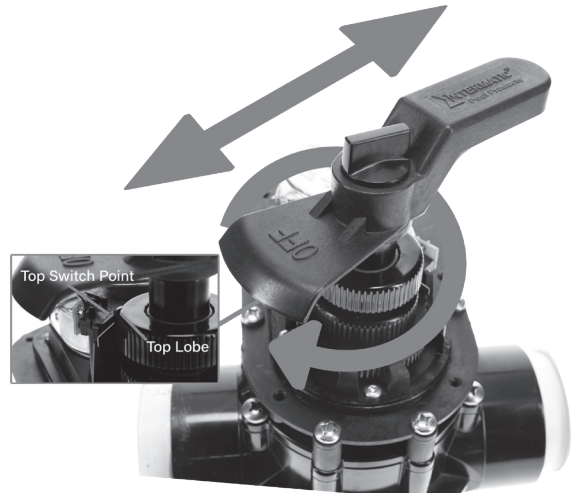

In this example, the flow has not been completely diverted at the stopping point.

3. Push down and turn the top cam to change the position of the stopping point.

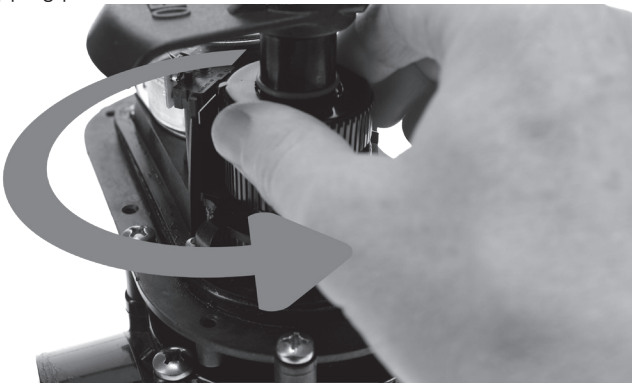

4. Test the position of the stopping point by toggling the bottom switch.

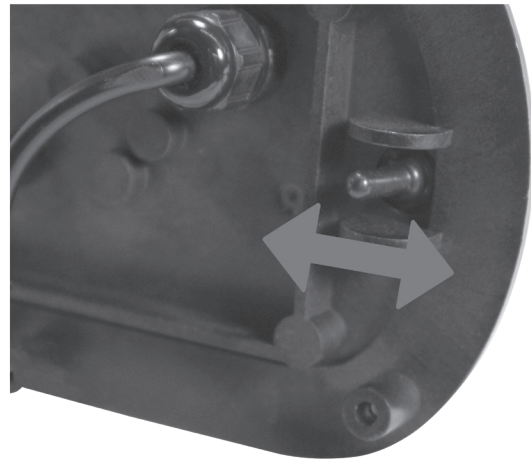

5. The flow in this example is now completely diverted at the stopping point.

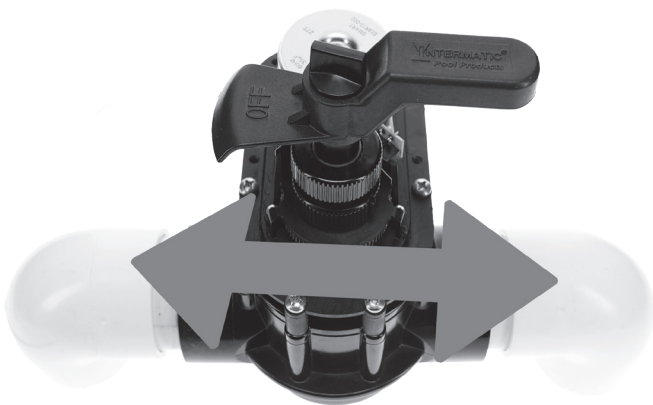

6. To check the counter clockwise stopping point, activate the bottom switch in the opposite direction.

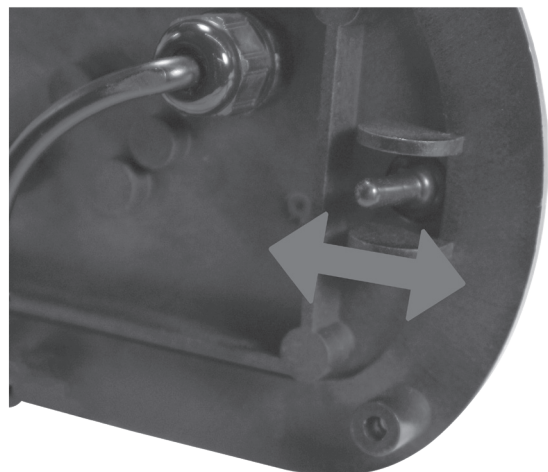

## CAM Setting Continued

7. Counter-clockwise rotation stops when the bottom cam lobe makes contact with the bottom switch point.

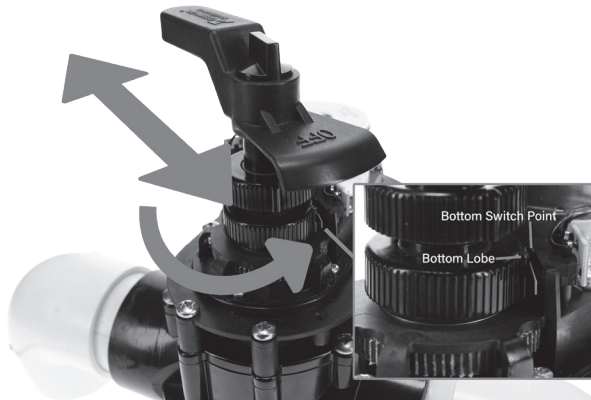

In this example, the flow has not been completely diverted at the stopping point.

8. Push down and turn the bottom cam to change the position of the stopping point.

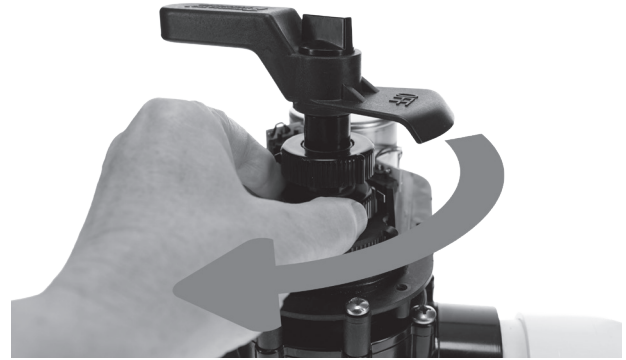

9. Test the position of the stopping point by toggling the bottom switch.

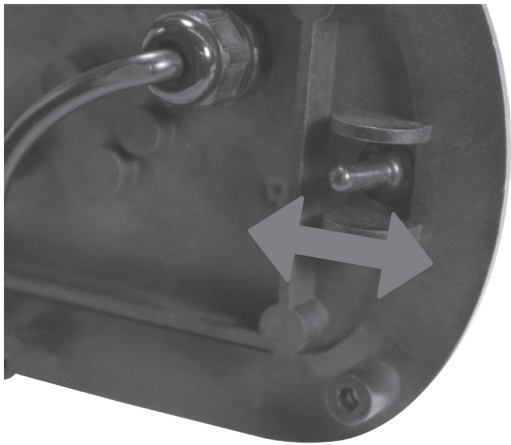

10. The flow in this example is now completely diverted at the stopping point.

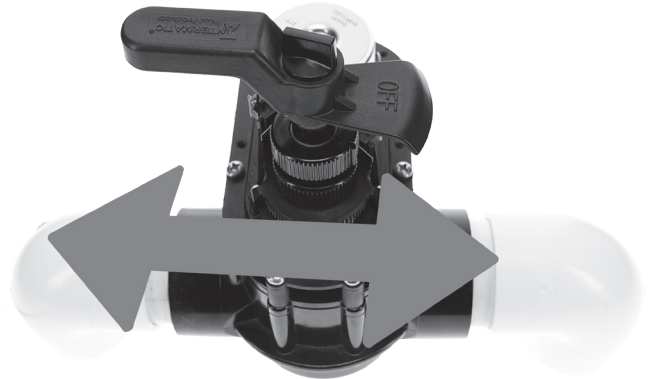

SCAN ME  
Scan QR code for Valve  
Actuator Cam Setting Video

## SYNCHRONIZATION

If one or more valve actuators are out of sync and rotating in the wrong direction, flip the three-position switch located on the bottom of the actuator to the extreme opposite switch position.

Doing this will reverse the rotation of the actuator and correct the issue. Unfortunately, you cannot fix this syncing issue by adjusting cams.

## OPERATION

During the normal operating season, the valves may need to be rotated manually, such as draining or filling the pool/spa. The valves can be rotated electrically or manually. If the system has power, rotate electrically. If no power, rotate manually.

### Rotating Valve Actuator Electrically

1. On the bottom of the Actuator, toggle the valve switch until the desired rotation is reached. See Figure 7 on this page.
2. Toggle the switch to the center (OFF) position to stop rotation.
3. Toggle the switch back to its original position.

### Rotating Valve Actuator Manually

1. On the bottom of the valve actuator, toggle the switch to the center (OFF) position.
2. Loosen the locking knob approximately four full turns.
3. Press down firmly on the locking knob to disengage the actuator gear train from the valve shaft.
4. This will allow the diverter valve to be moved to any position with the handle.
5. Pull up on the handle and turn it gently back and forth to return to the operating (drive) condition.
6. Tighten the locking knob (until snug) on the top of the handle and toggle the switch to its original Auto ON position.

## MAINTENANCE

### Servicing the Valve Actuator

The valve actuator seals need to be greased once a year.

UNSCREW HOLD DOWN KNOB AND REMOVE KNOB AND HANDLE. REMOVE SCREWS AND COVER. LUBRICATE WITH SILICONE GREASE IN ONE OR BOTH OF THE LOCATIONS AS SHOWN.

Unscrew hold down knob and remove knob and handle. Remove screws (6) and cover. Lubricate in one or both of the locations as shown.

**NOTE:** Use phillips head screwdriver to retighten screws.

Do not over tighten.



Figure 4.

### LIMITED WARRANTY

Warranty service is available by either (a) returning the product to the dealer from whom the unit was purchased or (b) completing a warranty claim online at [www.Intermatic.com](http://www.Intermatic.com). This warranty is made by: Intermatic, Customer Service 1950 Innovation Way, Suite 300, Libertyville, IL 60048. For warranty service go to: <http://www.Intermatic.com> or call 815-675-7000.

### INTERMATIC INCORPORATED

1950 Innovation Way, Suite 300  
LIBERTYVILLE, ILLINOIS 60048  
[www.Intermatic.com](http://www.Intermatic.com)